

EUROSTAR HS

MECHANICAL LEVEL FILLER



*Performance
through
Understanding*



EUROSTAR HS

VERSATILITY AND COMPLETE RELIABILITY

Great versatility is the hallmark of the Eurostar HS. The machine comes in both glass and PET bottle versions and is designed to fill carbonated and still beverages, beer and wine.

Eurostar HS is based on proven technology guaranteeing reliability, high performance, product quality and easy sanitization. As the HS name suggests, this machine offers high-speed precision filling and, in the case of beer, minimal oxygen in the bottle.

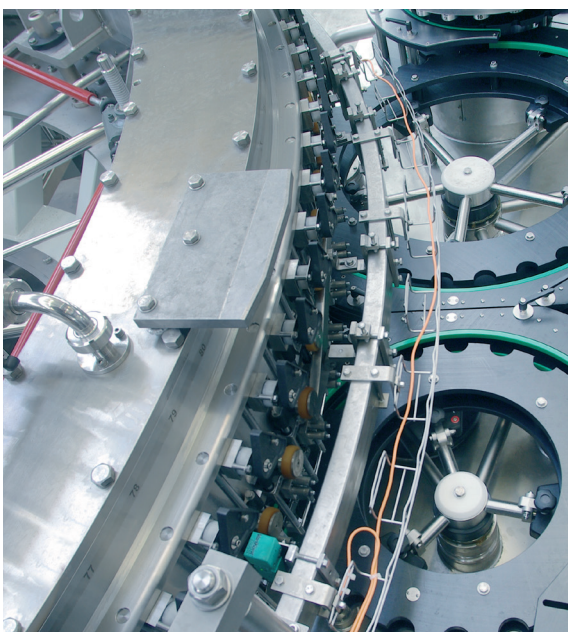
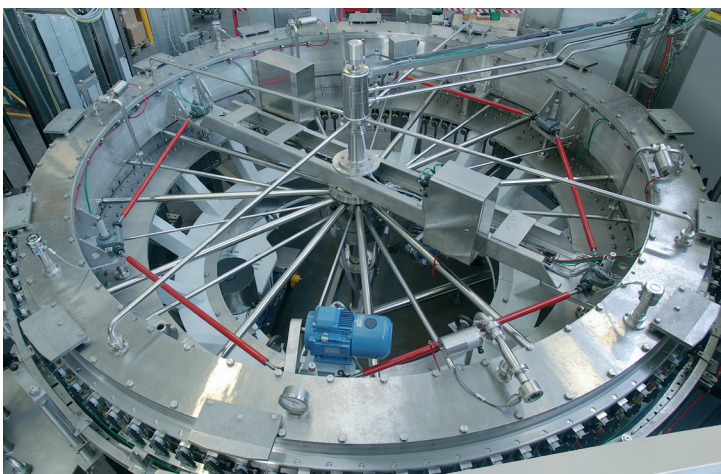



MAIN FEATURES

- High performance
- Reliability due to simple, proven mechanics
- Flexibility: handles glass or plastic bottles
- Easy sanitization
- Hygienic
- Easy machine access
- User-friendly operation
- Can be attached to a rinser

FILLING VALVE

SIMPLE DESIGN FOR EASY CLEANING AND MAINTENANCE

The mechanical filling valve has an extremely simple design with a limited number of components and gaskets. This guarantees easy sanitization and minimizes maintenance.

- The return springs are external, improving hygiene conditions and simplifying replacement
- The valve components can be dismantled independently, a maintenance advantage
- The interchangeable vent tubes are attached to the body of the valve ensuring rapid assembly and dismantling

FLEXIBILITY

The Eurostar HS has a wide range of applications. In addition to beer, wine and carbonated beverages, still products can be filled at atmospheric pressure thanks to the special valve design. Depending on the product and container to be filled, various versions of the valve are available:

- Without pre-evacuation: carbonated beverages or still water in glass or PET bottles
- With pre-evacuation: beer or CSD in glass bottles
- With double pre-evacuation: beer in glass bottles
- With self-leveling: wine in glass bottles
- With pre-evacuation and self-leveling: still or sparkling wine in glass bottles
- Up to two closing devices (crown and/or capper) can be located on the extended base-frame (available as an option).



Section of the filler

- product
- vacuum or CIP return
- CO2 or counter-pressure gas
- decompression

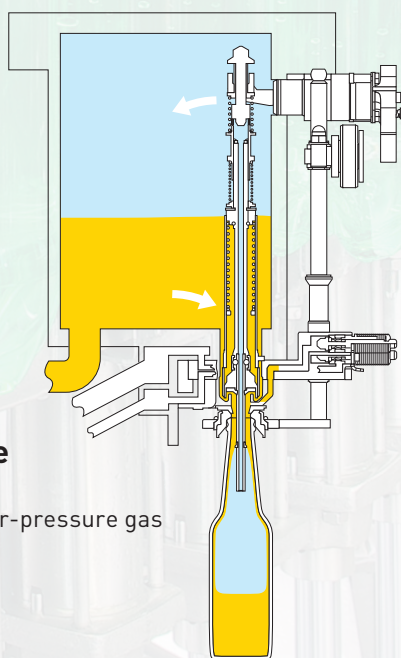
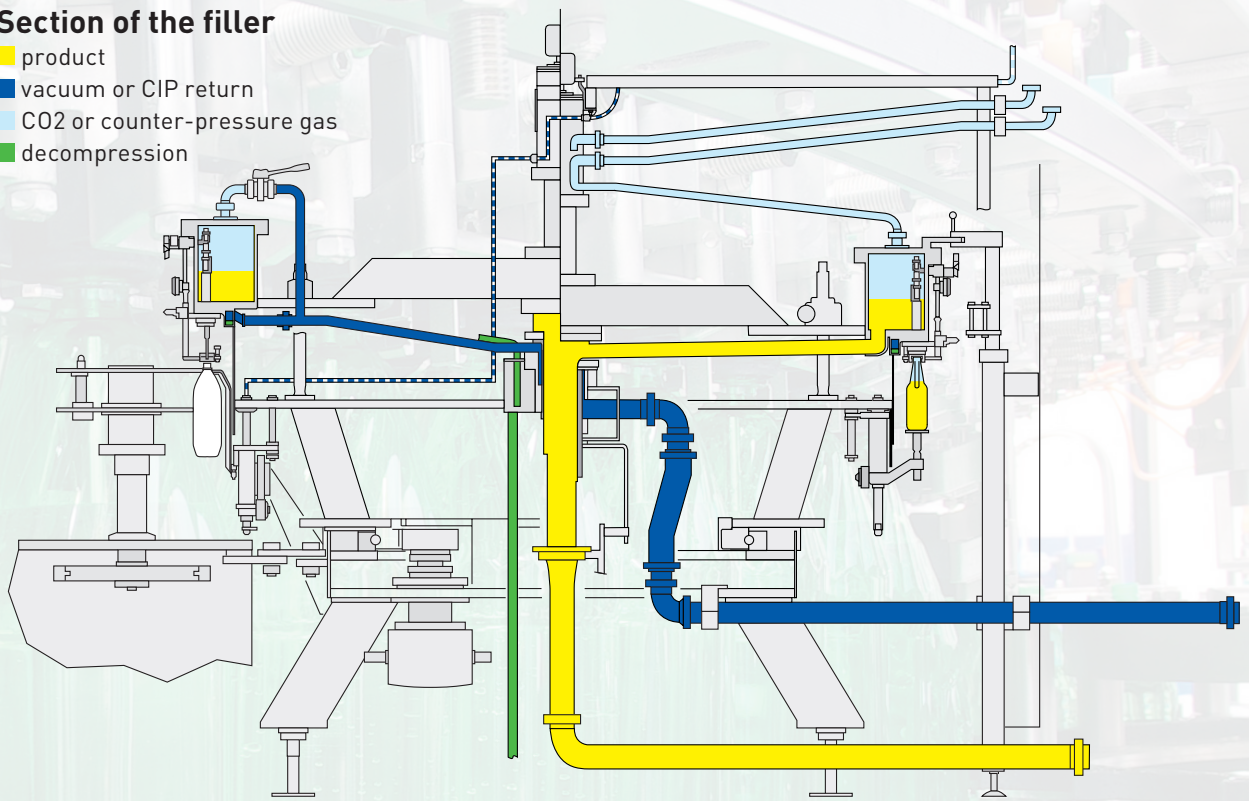

Filling phase

- product
- CO2 or counter-pressure gas

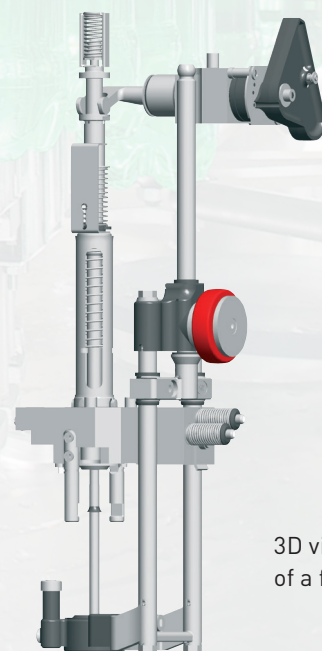

3D view
of a filling valve

FORMAT CHANGEOVERS

BOTTLE HANDLING

The format changeover is completely tool free, thanks to a quick turn of the handles of the starwheel and guides.

Optional guides quick changeover system with a quarter turn.

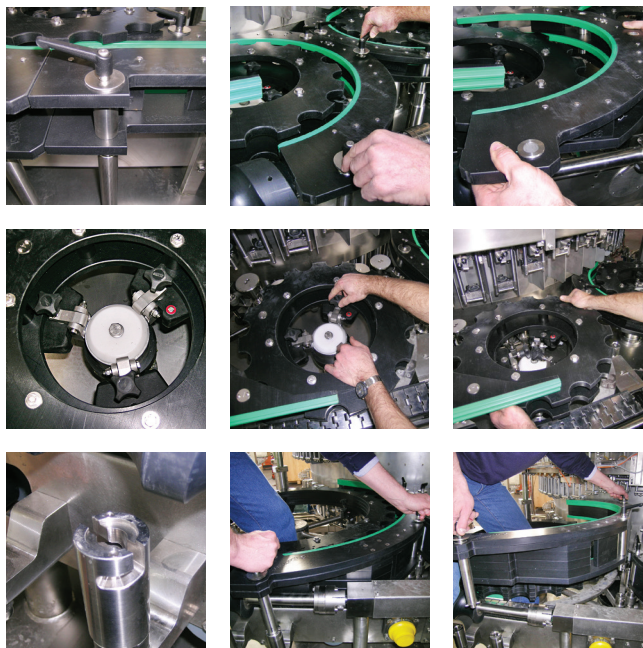

AUTOMATIC HEIGHT ADJUSTMENT

On request, the filler for glass bottles can be equipped with an automatic height adjustment system to adapt to the various bottle formats.

This feature guarantees high precision, repeatability, easy operation and minimal

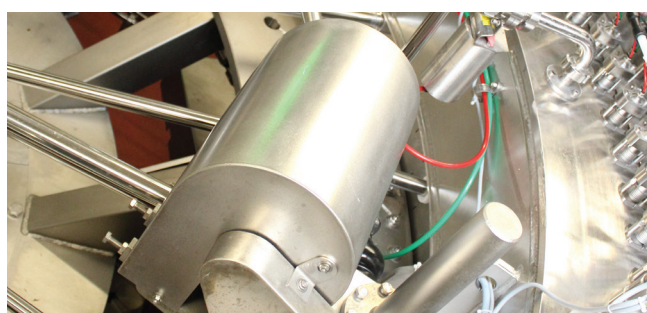
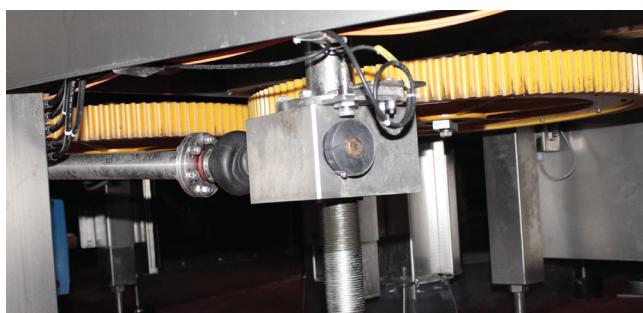

BOTTLE LIFTS

The bottle lifts are raised from above and are located inside the carousel where they are well protected. The design of the bottle lift makes for easier, faster assembly and dismantling, as these operations are carried out with the bottle lift completely assembled.

If a bottle bursts, the fragments of glass and product fall directly to the floor without coming into contact with the sliding parts of the bottle lift.

At the same time, an automatic wash-off system is switched on to spray high-pressure water jets onto the bottle lift plates, the filling valves and the centering bells which are lifted into the wash-off area, where any remaining glass debris is completely removed.



CLOSING SYSTEMS

CROWNER

The crowner offers both speed and flexibility as it can be adjusted according to the application.

- The machine can be fitted with a double hopper and double cap infeed chute to enhance efficiency: if the main chute jams, the second chute automatically starts, avoiding machine downtime.
- Also available in an ultra-clean version, the crowner is perfectly suited to applications requiring higher hygiene as it is specifically designed to make cleaning operations easier.
- As an option, both crown caps and ring-pulls can be used with quick changeovers.

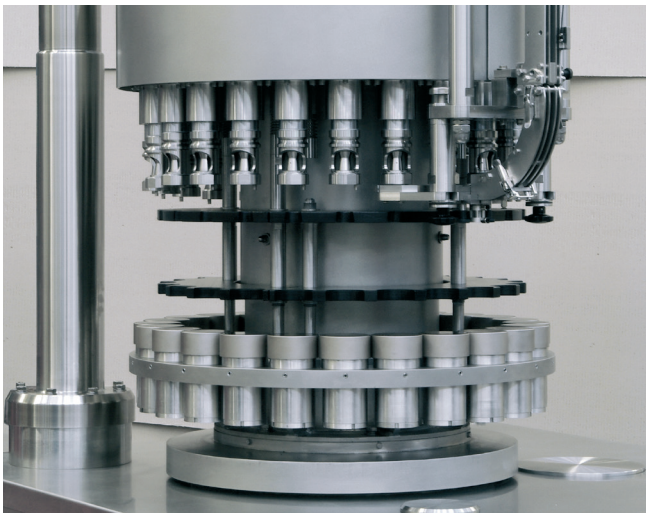

CAPPER

As an alternative or in addition to the crowner, one or more cappers can be installed to handle all types of screw caps:

- Aluminum caps
- Plastic caps
- Sport caps
- Special caps

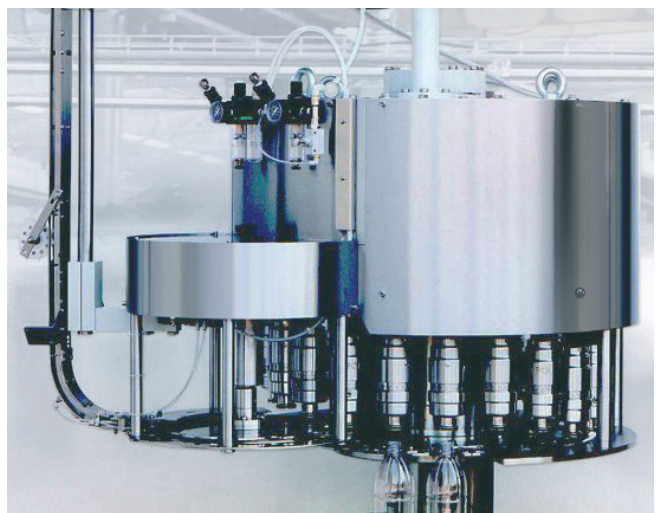

VARIABLE PRESSURE FOAMING SYSTEM



QUALITY FILLING

This foaming system is installed on fillers dedicated to beer. Residual air is eliminated from the bottle neck by injecting high pressure water before crowning. As an option, this system can be automated. The PLC software adjusts the pressure according to a pressure/speed graph set by the operator interface terminal. By memorizing the graphs, proper foaming is guaranteed in all working conditions. The system can also be integrated with an automatic device controlling the foam water temperature.

SANITIZATION

The machine is designed to be washed and sanitized in a closed loop, installing dummy bottles applied to the filling valves.

All parts in contact with the product are treated in the sanitization cycle. On request, an external sanitization system can be provided for the filler carousel and base frame. Any residue is removed by foaming products and water rinsing.

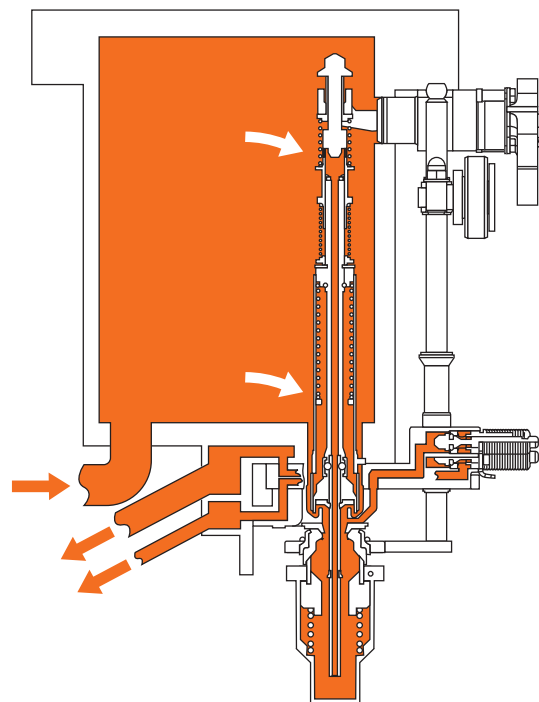

INTERNAL SANITIZATION

■ sanitizing product



SPECIAL APPLICATIONS

ULTRA-CLEAN BASE FRAME

On request, the front base frame can be supplied in an ultra-clean version, featuring a double slope on the upper surface.

This special design allows complete and rapid draining of all product residues, water, and broken bottles.

This makes cleaning operations easier, more effective and guarantees optimal hygiene conditions in the filling area.



OPERATOR INTERFACE

A PC with a touch-screen and graphic software provides simple, practical control over the machine.



Gebo Cermex works in partnership with Sidel as part of The Sidel Group. Together, we are a leading provider of equipment and services for packaging liquids, foods and personal care products in PET, can, glass and other materials.

With over 37,000 machines installed in more than 190 countries, we have nearly 170 years of proven experience, with a strong focus on advanced systems, line engineering and innovation. Our 5,000+ employees worldwide are passionate about providing complete solutions that fulfil customer needs and boost the performance of their lines, products and businesses.

Delivering this level of performance requires that we continuously understand our customers' challenges and commit to meeting their unique goals. We do this through dialogue, and by understanding the needs of their markets, production and value chains. We complement this by applying our strong technical knowledge and smart-data analytics to support maximum lifetime productivity to its full potential.

We call it *Performance through Understanding*.

170731 – The information in this document contains general descriptions of technical options available, which do not always have to be present in each individual case. The required features should therefore be specified in each individual case at the time of closing the contract. No part of this publication may be reproduced, stored in a retrieval system, or transmitted, in any form or by any means, without previous written approval by Sidel. All Sidel intellectual rights, including copyright, are reserved by Sidel. All other trademarks are the property of their respective owners.

gebocermex.com

**Performance
through
Understanding**

