

# ICS-CIP

**An integrated washing and sanitization system**



THE INTEGRATED CIP SYSTEM (ICS) IS AN OPTIONAL FEATURE WHICH CAN BE INTEGRATED INTO THE UNIVERSAL HIGH CLEAN (UHC) SKID OF VARIOUS FILLERS (MODELS: EUROTRONICA FM-S, EUROPA WM AND EUROPA W). CONCEIVED FOR IN PLACE PREPARATION AND HEATING OF WASHING AND SANITIZATION SOLUTIONS, THE ICS IS EQUIPPED WITH AN ELECTRIC HEATING SYSTEM (AVAILABLE ALSO STEAM HEATING) AND AN INDEPENDENT CHEMICAL DOSING SYSTEM.

# Integration

## Universal High Clean + Integrate Cip System

Only the quantities of detergent and disinfectant solution strictly necessary for washing the filler are used. The consumption of concentrates solutions is thus reduced to a minimum.

Sanitization with hot water also only uses the energy for heating the filler surfaces direct in contact with the product, avoiding all sort of heat loss.



# Main features

- Perfectly integrable
- no changes to standard space requirements
- components in AISI 316
- designed for subsequent extensions
- pre-assembled in our plant
- installed electric power starting from 48 kW
- all components in contact with product designed hygienically
- top-quality standard instruments
- components installed for greatest user-friendly maintenance
- concentrates solutions dosed by volumetric and conductivity methods
- chemicals unit can be installed at a distance
- complete management of washing recipes
- CIP control integrated in the filler automation.

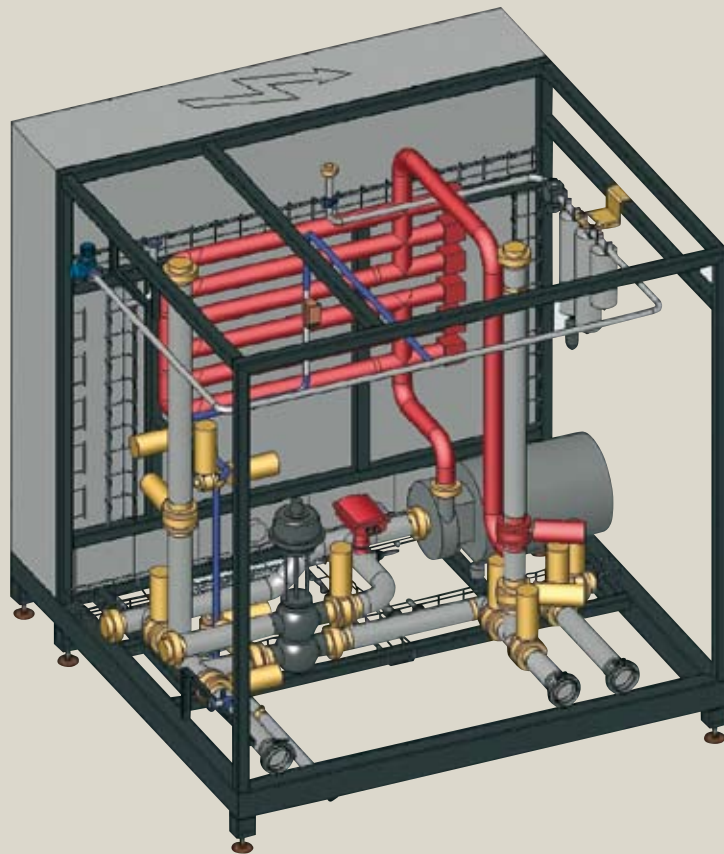

# Structure

## SKID

The **UHC modular skid** is pre-assembled and fully cabled. It contains all process components for the electric control and automation of the filler. Thanks to its standard dimensions for all models, the skid performances can be enhanced by additional optional features (fig. 1). All the services required for the filler are thus concentrated in one point. Similarly, all the connections to the filler converge on the skid.

The monoblock is equipped with:

- support frame for the panel with the electric and process components
- sanitary centrifugal pump
- sanitary pneumatic valves
- process and control instruments.

## THE ICS OPTION

The integration of the washing and sanitization functions has been considerably streamlined (fig. 2), and the heating and control instruments system included (in red) does not change the accessibility and dimensions of the skid. The standard heating system is electric, with the option of an indirect steam heat exchanger.

**Chemicals unit:** the detergent and disinfectant concentrates are dosed by an independent unit ensuring the accurate titration of the solutions circulating in the filler (fig 3).

Up to three different types of chemicals can be used, and dosing may be selected according to the V/V ratio or by an inductive conductivitymeter installed on the skid. The solutions are aspirated from the containers by a flexible nozzle with an end valve and filter.

The unit consists of a pneumatic membrane pump for automated dosing and transfer, a pneumatic membrane valve for each chemical, and another membrane valve for rinsing the pipes after each dosage. The quantity of chemicals dosed is measured by a vortex flowmeter.

The container tanks have a discharge valve for the drums of concentrates, installed on the support integrated in the machine.

All components in contact with the concentrates are in AISI316 and PTFE. The Siemens S7 automation technology is integrated with a Festo pneumatic module.

The whole chemicals unit is mounted in suitable AISI304 casing with see-through doors for checking on possible leakage. The unit can be installed alongside the skid or up to a distance of 30 m. away.

**Sanitary instruments** consist of an inductive conductivitymeter with integrated temperature transmitter.

**Electric heating** with resistances inserted in corrugated pipes to enhance heat exchange; installed power from 48 to 110 kW for a filler with 40 -120 valves.

Also available is an indirect steam heat exchanger (500,000 kCal/h) with an electro-pneumatic regulating valve and a steam trap.

**Piping:** the tees, elbows, and connections are in AISI 316, polished, with standard DIN 11851 or clamp fittings. All the external and internal welding is carried out in an 99.9% inert gas shielded arc, externally polished with a 100/150 no. 4 grain finish. Dead legs from the main pipes to instruments or other functions are at most 1.5 times the diameter of the main pipe. The design of the pipe connections ensures easy maintenance and, when necessary, the joints can be easily dismantled.

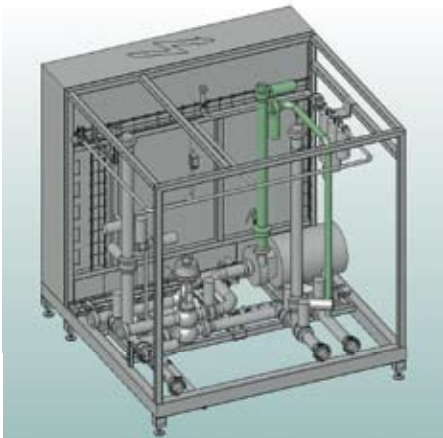

Fig. 1

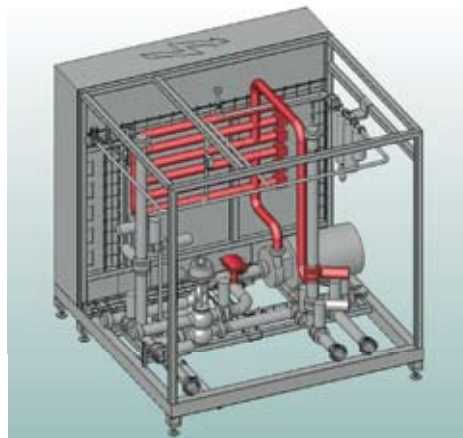

Fig. 2

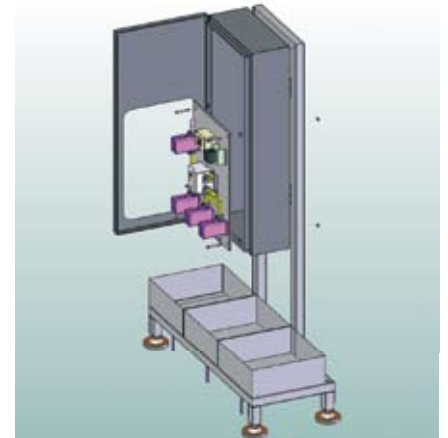

Fig. 3



# The process

The **ICS** option ensures washing, disinfecting and hot water sanitizing with minimum consumption of energy and chemicals.

Since the washing solution **only** flows between the filler and the skid, the quantity of liquid used is always the **minimal** indispensable to circulate.

The **UHC** skid allows the filler tank to be washed by spray balls. The quantity of solution circulating during

the cleaning phases is thus from 200-300 liters. With the **ICS** option the volume of solution titrated and heated is thus **reduced** in real terms.

During washing, the rising and filling phases use the water from the production line. This means the filler is **rapidly** available after final rinsing, because the same bottling water is used without resorting to an external CIP tank.

Heating is also more **efficient** because of reduced surfaces dispersing heat. Washing times are **shorter** since there are no long connecting pipes to the CIP unit normally requiring filling and rinsing operations.

The quantity of used solution to be discharged at the end of the cycles is thus never more than the quantity

normally consumed by a centralized CIP because of the inevitable dilutions in the connecting pipes.

Savings are also made in chemical concentrates, thanks to accurate dosing. The measurements can be operated by a conductivitymeter, and by a flowmeter when conductivity is not significant (e.g. peroxyacetic acid disinfectants).

## Layout

- 1 - pneumatics filler utilities
- 2 - rupture disc
- 3 - pneumatics skid utilities
- 4 - compressed air inlet
- 5 - steril air inlet
- 6 - nitrogen gas inlet
- 7 - water inlet
- 8 - CIP discharge
- 9 - electric heating exchanger
- 10 - exhaust gas discharge
- 11 - block and bleed drain
- 12 - bleeds drain
- 13 - chemicals unit
- 14 - APA/PAA disinfectant sanitizer
- 15 - alkaline detergent
- 16 - acid descalant

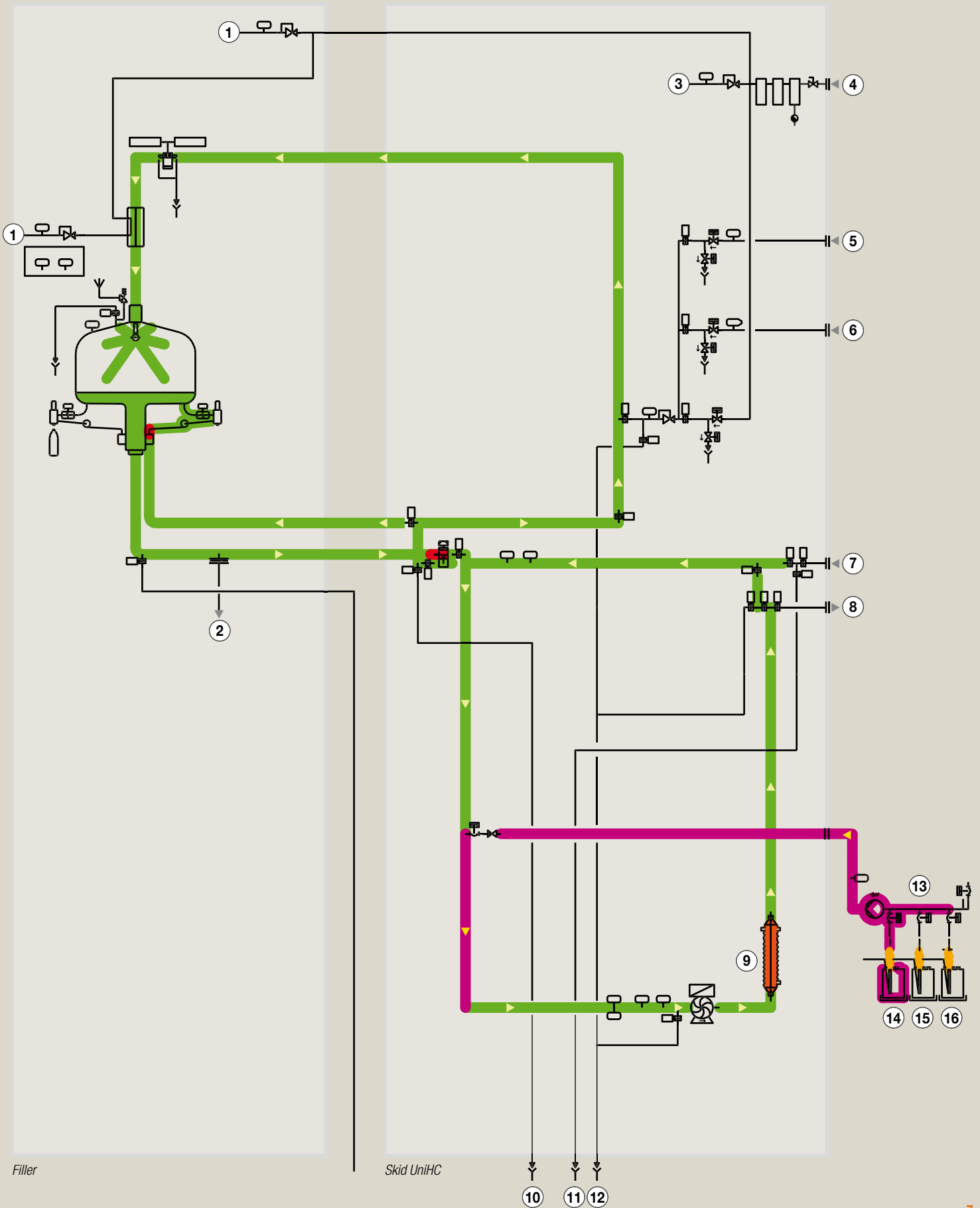

Filler

Skid UniHC



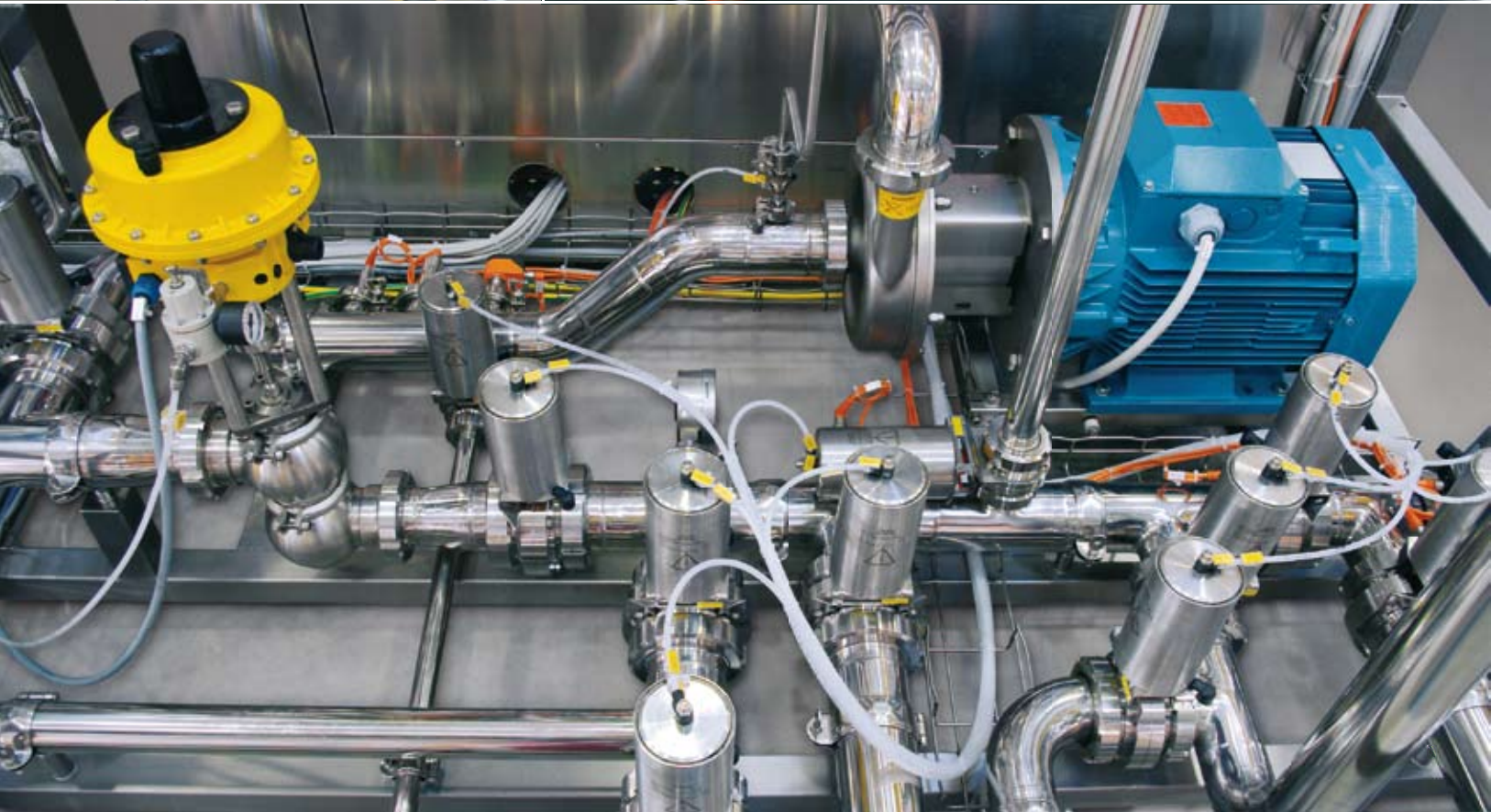
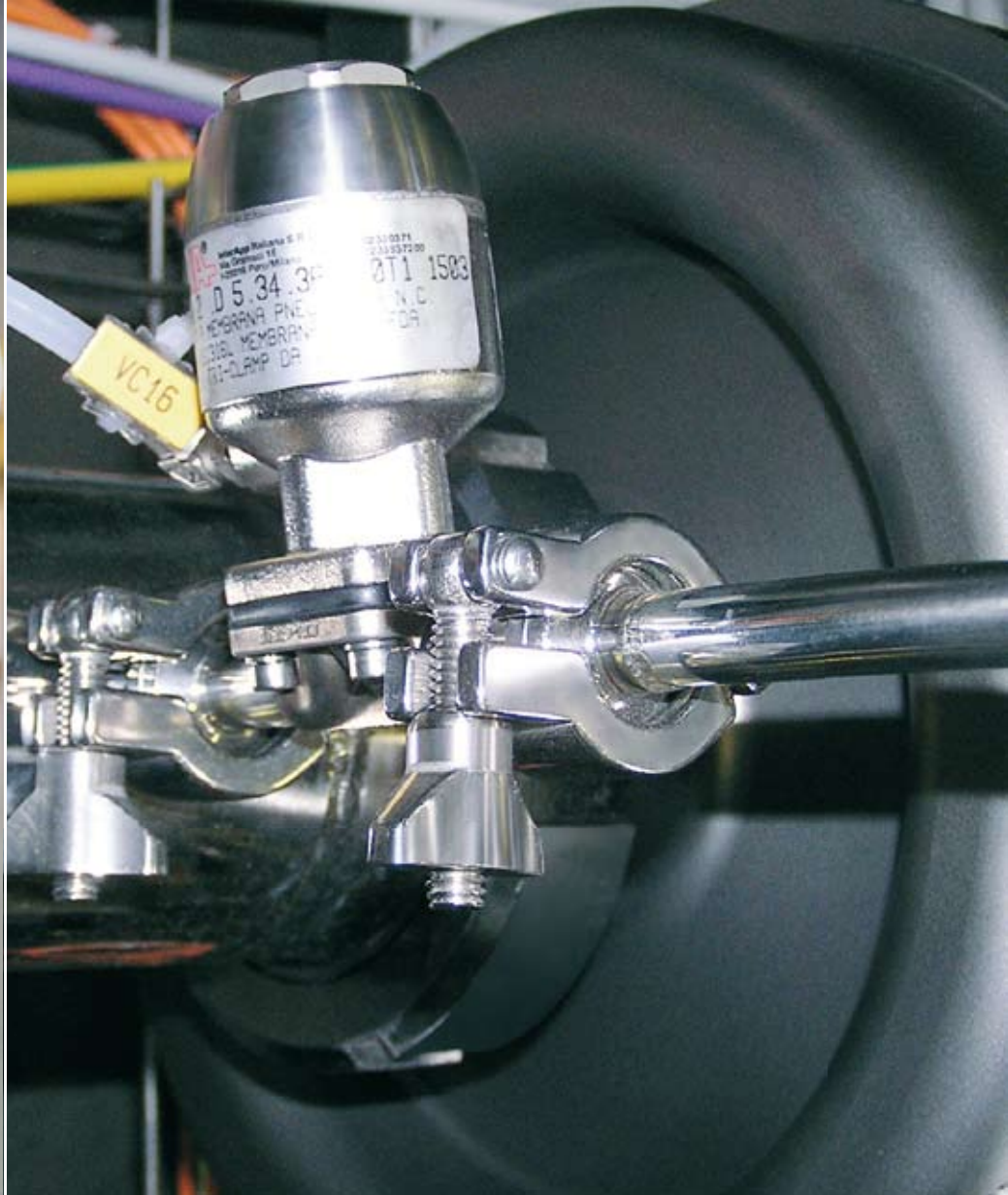

# ICS performance

Cleaning solutions can be preset and enable also, an immediate sequence of cycles:

1. rinsing from the production line

2. hot sanitary operation max 95°C

3. disinfecting operation by PAA/ APA min 0,1%

4. caustic cleaning operation

5. acid descaling operation

6. final rinsing from the production line.

Timing and temperature of the cycles

and the concentration of chemical solutions can be preset.

Other programmes can be approached on request.

## Technical data, heating time for different vessels and power

### Electical tubular heat exchanger model E1

Time to warm up the water from 15°C to 90°C according to the vessel volume and electrical power

Volume filler	200 litres from 40 to 50 filling valves
Electrical power	48 kW
Heating time	35 minutes
Flow speed	30,000 l/h

### Electical tubular heat exchanger model E2

Time to warm up the water from 15°C to 90°C according to the vessel volume and electrical power

Volume filler	300 litres from 60 to 90 filling valves
Electrical power	72 kW
Heating time	35 minutes
Flow speed	50,000 l/h

### Electical tubular heat exchanger model E3

Time to warm up the water from 15°C to 90°C according to the vessel volume and electrical power

Volume filler	350 litres from 100 to 120 filling valves
Electrical power	110 kW
Heating time	45 minutes
Flow speed	60,000 l/h

### Steam tubular heat exchanger model ST0

Time to warm up the water from 15°C to 90°C according to the vessel volume and steam pressure

Volume filler	200 to 350 litres from 40 to 120 filling valves
Steam consumption at 4 bar	500 kg/h
Heating time	15 to 25 minutes
Flow speed	30,000 - 60,000 l/h



